

## PANEL SAW SAFETY CHECKLIST

Revised 11-5-2020

(Display near panel saw)

1. Have you been shown a safe method for properly performing this operation?
2. Reviewed owner's manual?
3. What path will blade follow? **KEEP HANDS AWAY!**
4. Consult your supervisor if uncertain of proper operation.
5. Wear safety glasses.
6. Keep all safety guards in place and operable.
7. Disconnect electrical power before servicing saw.
8. Check blade – Right size? Correctly mounted? Clean? Sharp?
9. Turn saw motor up or down when ripping, pass materials against blade direction

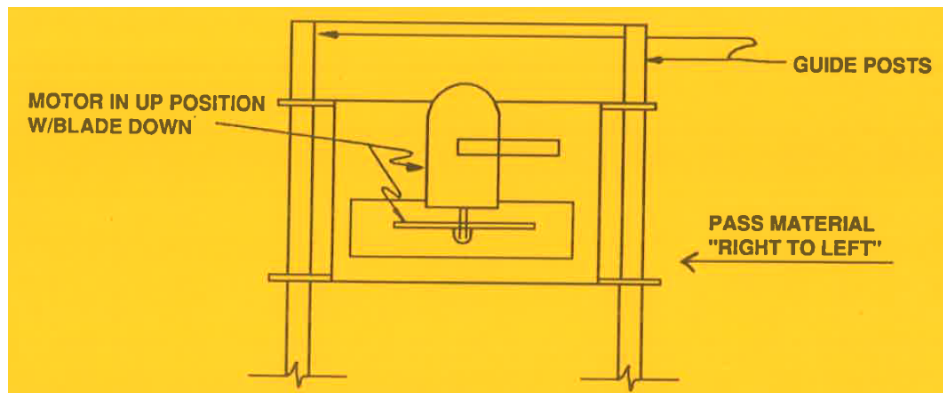

10. Notify Jones Machinery (888) 755-3377 – If saw is functioning improperly.
11. Do not let saw motor return rapidly to top after making a cut.
12. Do not permit customers to assist or use panel saw.
13. Do not operate saw if you are wearing loose clothing, ties, gloves or jewelry.
14. Do not force feed material through saw when ripping – allow saw to maintain maximum RPM at all times.
15. Do not force saw through the material when cross cutting.
16. Do not drop sheet stock on end roller of saw.
17. Do not drop top section of sheet material on saw after ripping.
18. Do not allow sheet material to start jumping while cutting.
19. Do not cut drywall on panel saw.
20. **CONCENTRATE – AVOID DISTRACTION – SAWS CAN'T THINK – YOU MUST!!!**



*Your Company Logo Here*